

RECOMMENDED SEAT POSITIONS

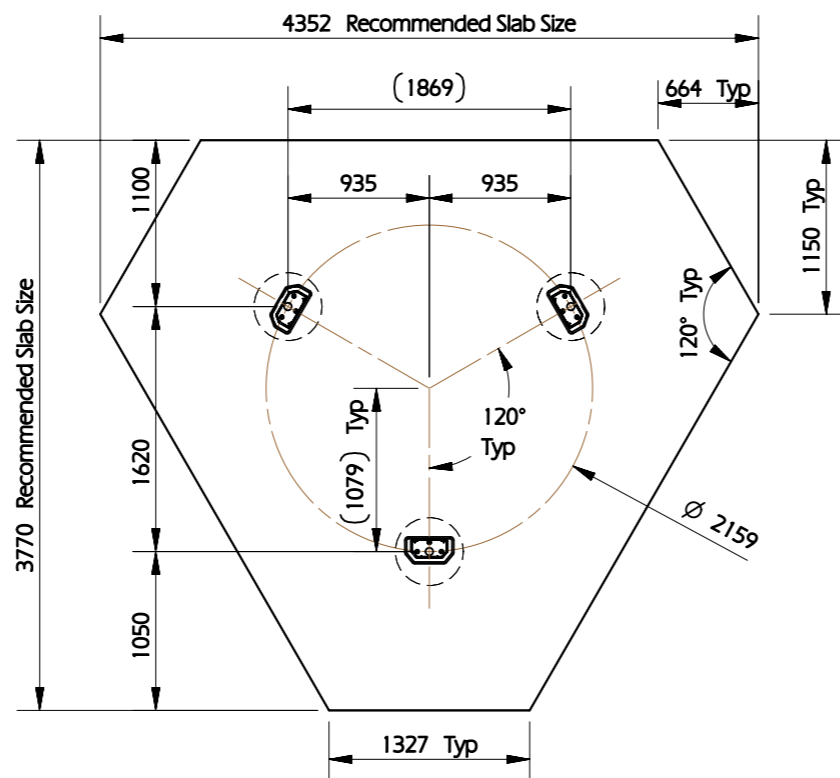

SECTION A-A
SCALE 1:50

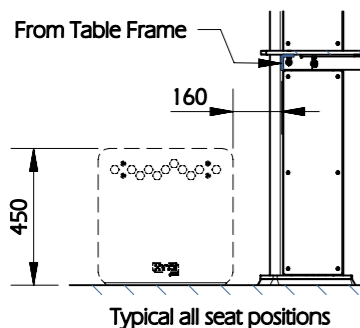
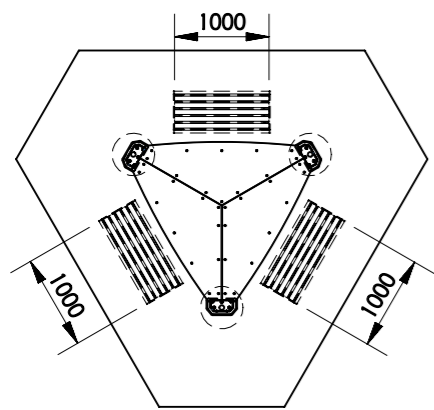
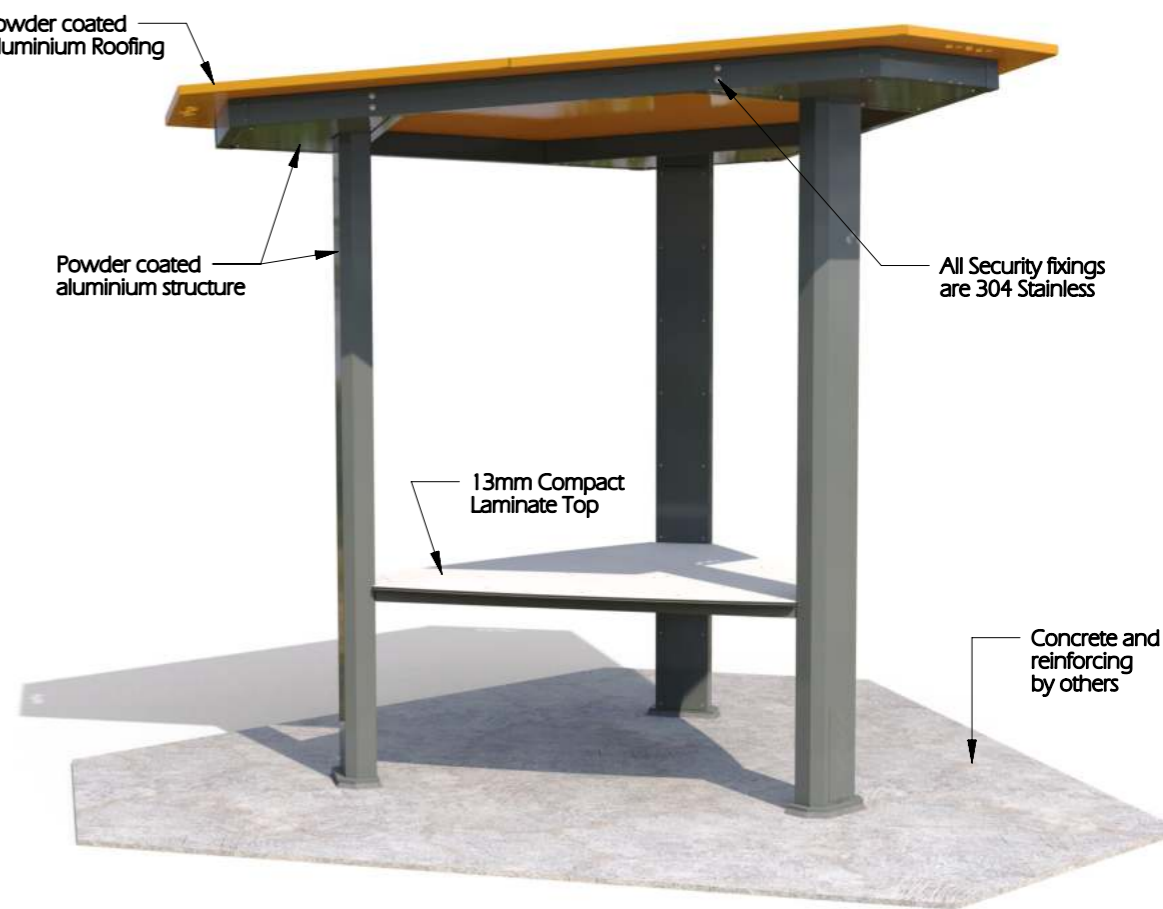

PICTORIAL VIEW

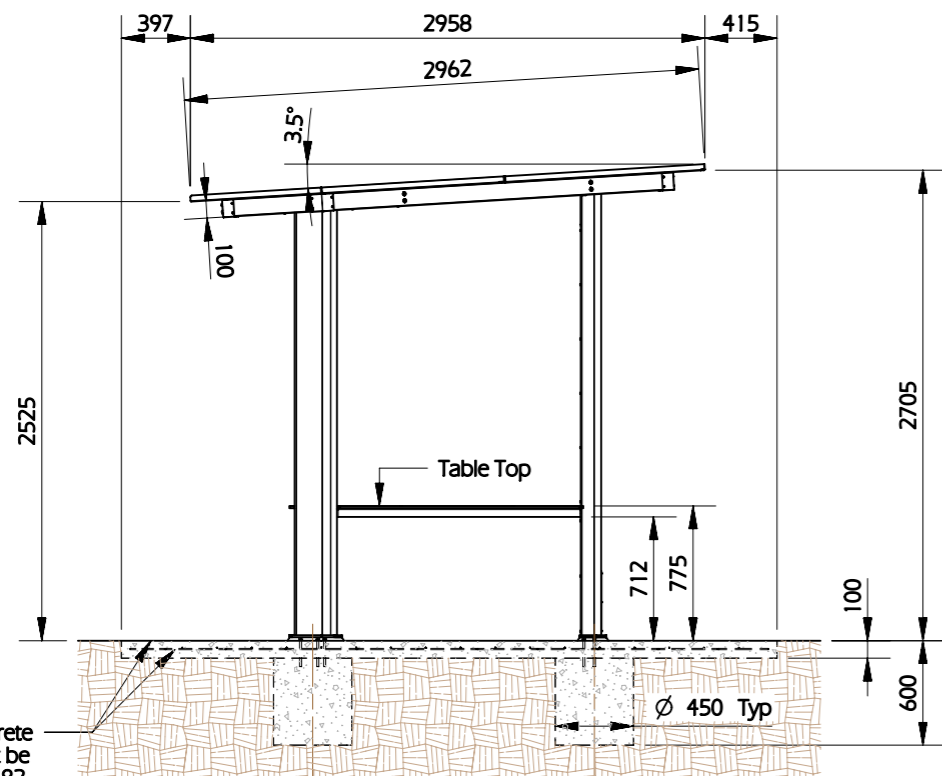

SIDE VIEW

Use 24 MPa concrete for slab. Slab must be reinforced with SL82 mesh 40mm below top of slab. (Concrete and reinforcing by others)

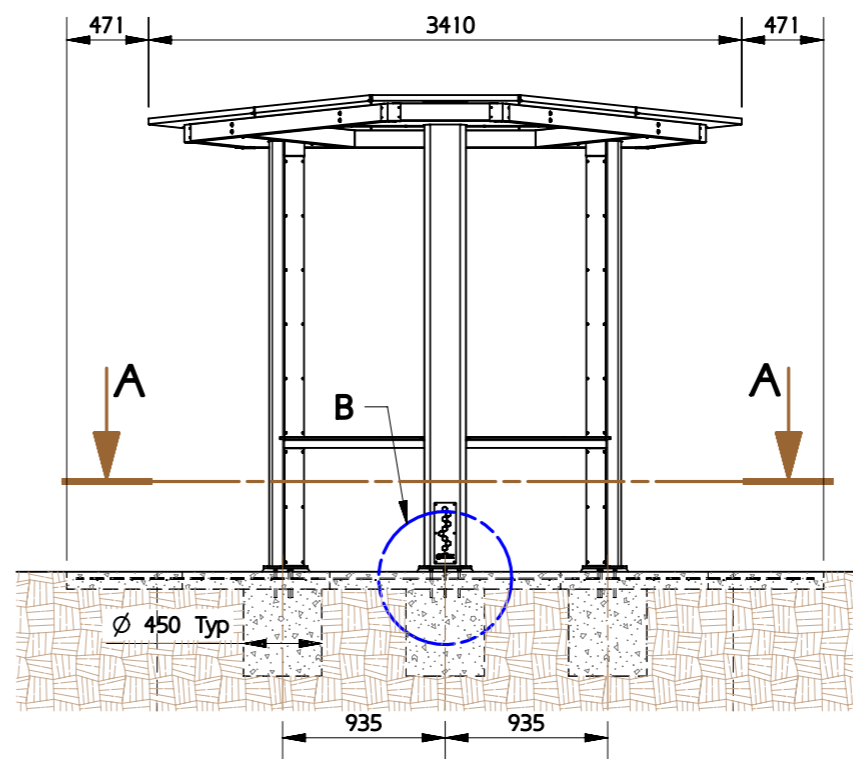

ELEVATION

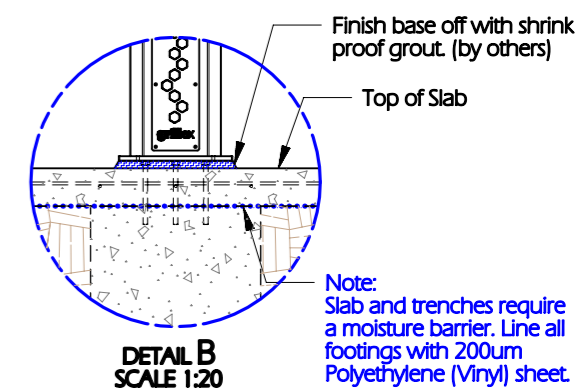

DETAIL B
SCALE 1:20

GENERAL NOTES:

1. Slab & reinforcing designed for soil Class "P"
2. Slab & trench footings to be lined with 200um Polyethylene (Vinyl) sheet (by others)
3. Compact subgrade to 95% and minimum bearing capacity of 100kPa. Deepen with 15MPa binding concrete if required.